

Things get Steamy at Aprilaire LIGHT COMMERCIAL PRODUCT



Aprilaire Model 1160
Electric Steam Humidifier

Features:

- **Installation flexibility** — A short absorption distance allows installation in tight duct configurations and each Aprilaire Steam Humidifier includes everything you need to complete your job.
- **No water supply hassles** — Aprilaire Steam Humidifiers are compatible with both standard tap and softened water, allowing installation in any application. The amount of water in the humidifier is continuously monitored electronically to ensure top performance.
- **Carefree maintenance** — The steam chamber is made of stainless steel with continuously welded seams and requires no cleaning for up to three seasons when supplied with appropriate softened water.
- **Long service life** — All internal components — such as the alloy sheathed immersion heaters, contactors, power relays and transformers — are high quality, industry proven parts designed to provide reliability and long life.

Aprilaire's line of light commercial humidifiers just got steamy... with the addition of two new electric steam humidifiers designed specifically for the light commercial market. The new models are:

MODEL 1150

- Featuring on/off control and a capacity of 12 lbs/hr

MODEL 1160

- Featuring modulating control and a capacity of 24 lbs/hr

- **Durable and attractive** — The stainless steel frame and housing are designed to exceed all application requirements and complement any environment.

On/Off vs. Modulating Control

The Model 1150, 12 lb/hr unit features an on/off control that will send a 10 vdc signal to turn the unit completely on at 100 percent output.

The Model 1160, 24 lb/hr unit features a modulating time proportioning control that will send a signal within the range of 0-10 vdc, with 0 being "Off", and 10 being 100 percent "On." This works by measuring how far the actual building RH is away from set point and sending the appropriate signal to the humidifier. This modulation is referred to as time based, or time proportional. This means that the heaters will come on at 100 percent and then be cycled on and off to achieve the desired humidifier output.

In Stock Now

These units are in stock and ready for immediate shipment or pick-up at your Aprilaire distributor. So from now on, when your light commercial projects require humidification, quote Aprilaire. ■

Humidifiers: Portable vs. Whole-Home

SALES OPPORTUNITY

The October issue of *Consumer Reports*[®] features an article on portable humidifiers that includes a sidebar story on in-duct whole-home humidifiers. The article is very critical about the inconvenience, maintenance and noise output of the portable units. There are many inherent benefits for in-duct humidifiers:

1. No filling
2. No noise
3. No chemicals
4. Low, simple maintenance
5. Accurate humidity control
6. Whole-home capacity
7. Located out of the living space

Although in-duct models were not rated, they were ranked on output, based on their in-house testing - the Model 400 ranked first and the Model 600 ranked third. It is important to point out that the Aprilaire Whole-Home Humidifiers were the only units that featured an outdoor temperature sensor, which was determined to be important by *Consumer Reports*.

We encourage you to pick up a copy of the publication. Your customers will benefit in many ways:

- In a home with portables or a console –impress upon them the importance of using a whole-home unit for accurate humidity control and comfort. Just set it and forget it.

- The advantages of whole-home units versus a portable are clear
- Aprilaire Models are the best units in both capacity and features and most important, accuracy of control for maximum comfort.

Consumer Reports brings up a number of concerns with portable humidifiers, all of which are addressed with the installation of an Aprilaire Whole-home Automatic Humidifier. ■

Model 8570 - Did You Know?

Did you know that when you install an Aprilaire Automatic Humidifier along with a Model 8570 Thermostat that you can:

- **View** both indoor relative humidity and outdoor temperature at the thermostat
- **Extend** blower operation at the end of a heat call for more humidifier run time
- **Display** when the humidifier is operating and when its time to change the water panel

Your customers will appreciate the added comfort and convenience.

Give yourself an extra wire with the Aprilaire Model 8022

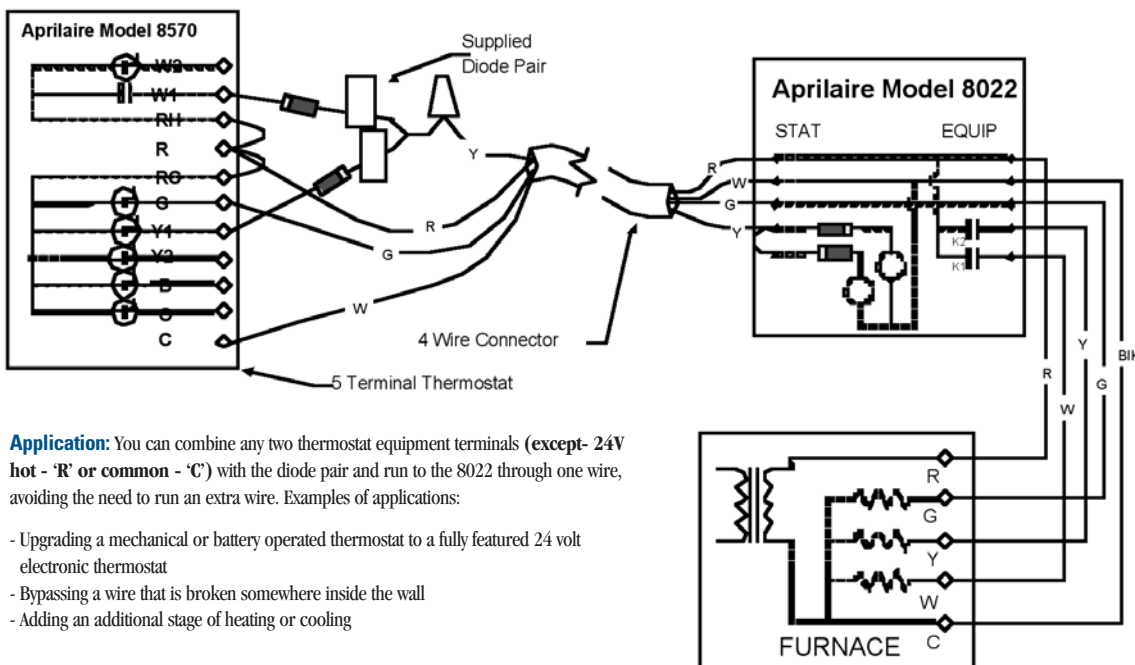

You're installing a new electronic thermostat in place of an old battery powered or mechanical thermostat. Unfortunately, the new thermostat needs five wires and you only have four available from the old style thermostat.

What do you do?

Grab an Aprilaire Model 8022. Always keep a spare in your tool box. It's a simple solution to an age old problem. ■

Application: You can combine any two thermostat equipment terminals (except- 24V hot - 'R' or common - 'C') with the diode pair and run to the 8022 through one wire, avoiding the need to run an extra wire. Examples of applications:

- Upgrading a mechanical or battery operated thermostat to a fully featured 24 volt electronic thermostat
- Bypassing a wire that is broken somewhere inside the wall
- Adding an additional stage of heating or cooling

Maximizing Dehumidifier Performance

TECH TIP

Q: How can I install the Model 1700 Dehumidifier to get the most possible moisture removal?

A: To achieve the maximum amount of moisture removal adjust the airflow through the unit to 275 cfm. A setting of greater or less than 275 cfm will result in less moisture removal.

The easiest and quickest way to control the airflow is to install a manual damper at either the outlet or the inlet of the dehumidifier. Then, using a device to measure the static pressure differential across the unit, set the damper so that the difference in the two pressure readings is 0.6" water gauge. This will deliver 275 cfm. [Example: suppose you measure 0.4" on the supply side and -0.2" on the return side. The static pressure differential is 0.4 minus -0.2, for a total static pressure differential of 0.6".]

The blower in the dehumidifier is strong enough to deliver 275 cfm with 150 equivalent feet of duct, so you may need to throttle

Model 1700 Dehumidifier Moisture Removal vs. Airflow

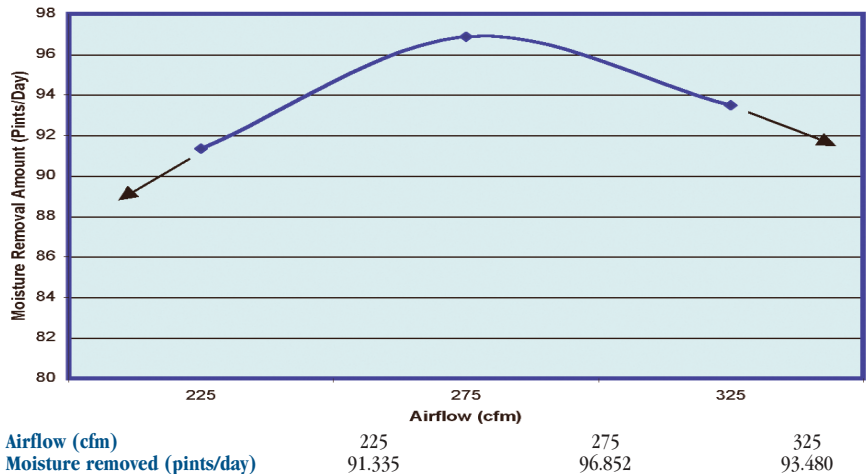

down the damper significantly if the installation does not use a lot of ductwork.

If the static pressure differential is too high, and you are using flex duct, check to see if the following might be happening:

- , The flex is too short, causing sharp bends and kinks. In this case, reinstall with longer flex and correct the bends and kinks.

- , The flex is too long, causing sags and bunching. If so, shorten and properly support the flex.

Correcting these problems will result in a lower static pressure differential. ■

Air Cleaners Add to Every Job

SALES OPPORTUNITY



Aprilaire Model 2200 Whole-Home Air Cleaner

When you are quoting a system replacement, this is the one time when you can be sure the homeowner is interested in hearing about whole-home air cleaners.

How do you know they're interested?

- , Consumers buy millions of room air cleaners each year at prices that cost almost as much as an installed unit.
- , Feedback from experienced dealers tells us that 4 out of 10 homeowners will buy an air cleaner if it is quoted.

, A recent survey of homeowners shows that less than 1 in 10 knows that whole-home air cleaners exist, but when asked to describe the perfect air cleaning solution for their home, they describe the features of an Aprilaire Whole-Home Air Cleaner:

1. Installs in the system - out of sight
2. Cleans the air in the entire house, removing a high percentage of allergens and dust
3. Is completely silent
4. Only has to be maintained once a year

How can you do this?

- , Include Aprilaire Air Cleaners on every system replacement quote.
- , Call your Aprilaire District Sales Manager. He offers training to help build your business.
- , Call us! We have free sales literature targeted at the consumer, helping you make the points raised above. ■

Aprilaire®

Fresh Ideas for Indoor Air®

P.O. Box 1467 • Madison, WI 53701-1467
1-800-334-6011

www.aprilairecontractor.com

PRSRST STD
US POSTAGE
PAID
MADISON WI
PERMIT #2944

Good Housekeeping® Reports Features CO Test Kit



Don't miss an exceptional sales opportunity that can be a part of every service call or tune up. Aprilaire Detectagas is the safe, effective way to confirm your customers on-going safety through carbon monoxide (CO) alarm testing.

The Good Housekeeping Institute has released its latest news segment focusing on CO alarms and the dangers of the deadly gas. The segment also features the Aprilaire CO Test Kit as a recommended service tool to ensure alarms in the home are working properly. Good Housekeeping directs viewers to call a local contractor to have this service performed. This news segment will run on news stations across the country for the next several weeks.

If your customer doesn't have a CO Alarm or it fails the test-offer them the quality, UL approved Aprilaire Model 1800 CO Alarm. ■

Let Us Know...

We welcome any comments and suggestions that you may have.

Please direct them to ndk@aprilaire.com (refer to Dealer Newsletter in the subject line).